

BRADEN

PCD24B HYDRAULIC PLANETARY CAPSTAN DRIVE

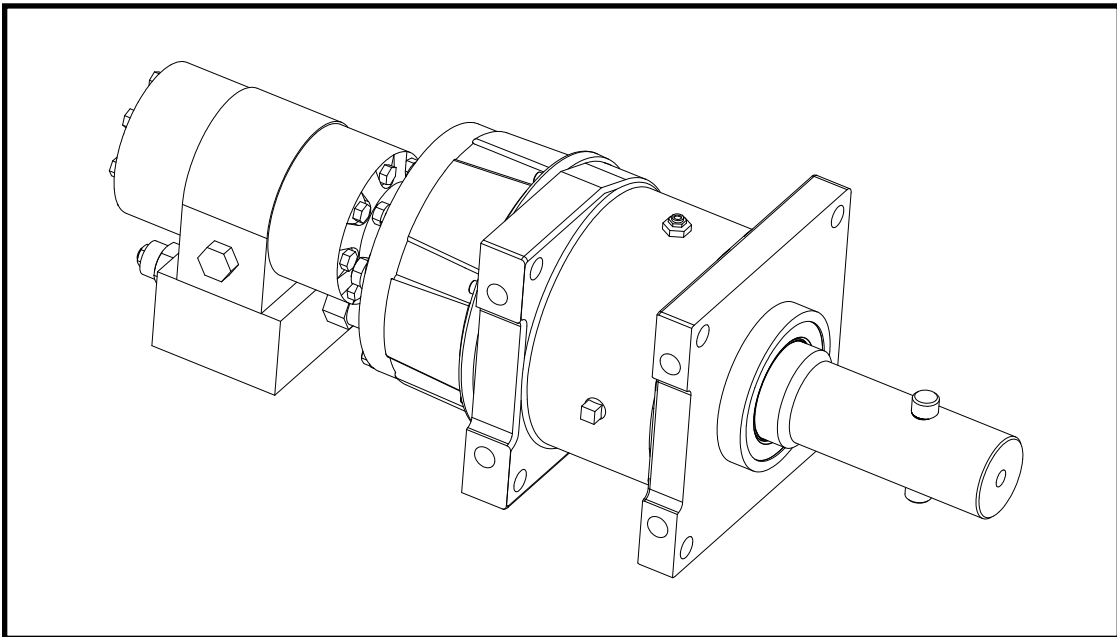

INSTALLATION, MAINTENANCE AND SERVICE MANUAL

TABLE OF CONTENTS

	PAGE
FORWORD.....	2
EXPLANATION OF MODEL NUMBER	2
GENERAL SAFETY RECOMMENDATIONS	3
THEORY OF OPERATION.....	4
DRIVE INSTALLATION	5
TYPICAL INSTALLATION DIMENSION DRAWINGS	6
HYDRAULIC CIRCUITS.....	6
PREVENTIVE MAINTENANCE.....	7
RECOMMENDED PLANETARY GEAR OIL	8
UNIT WEIGHTS	8
TROUBLE SHOOTING	9, 12, 13
EXPLODED VIEW DRAWING AND PARTS KEY.....	10-11
CAPSTAN DRIVE SERVICE	14
DRIVE DISASSEMBLY	14
PLANET CARRIER SERVICE	15
STATIC BRAKE SERVICE	16
CAPSTAN DRIVE ASSEMBLY	17
BOLT TORQUE CHART.....	20
METRIC CONVERSION TABLE	21

FOREWORD

Read this entire publication and retain it for future reference.

If you have any questions regarding your Braden Capstan Drive or this publication, call the BRADEN Service Department at 1-918-251-8511, 8:00 am to 4:30 pm Central Time, Monday through Friday.

The minimum service intervals specified are for operating hours of the prime mover.

The following service instructions have been prepared to provide assembly, disassembly and maintenance information for the BRADEN Model PCD24B Planetary Capstan Drive. It is suggested that before doing any work on these units, all assembly and disassembly instructions should be read and understood.

Some illustrations in this manual may show details or attachments that are different from your drive. Also, some components have been removed for illustrative purposes. Illustrations and pictures in this manual are of a "typical" unit sold through our distribution channels. Some drives, particularly those sold directly to original equipment manufacturers, may differ slightly in appearance.

Whenever a question arises regarding your BRADEN Drive, please contact the BRADEN Service Department for the latest available information.

The capstan drive Serial Number and Model Number are stamped into the housing at the location shown. Always refer to these numbers when requesting information or service parts.

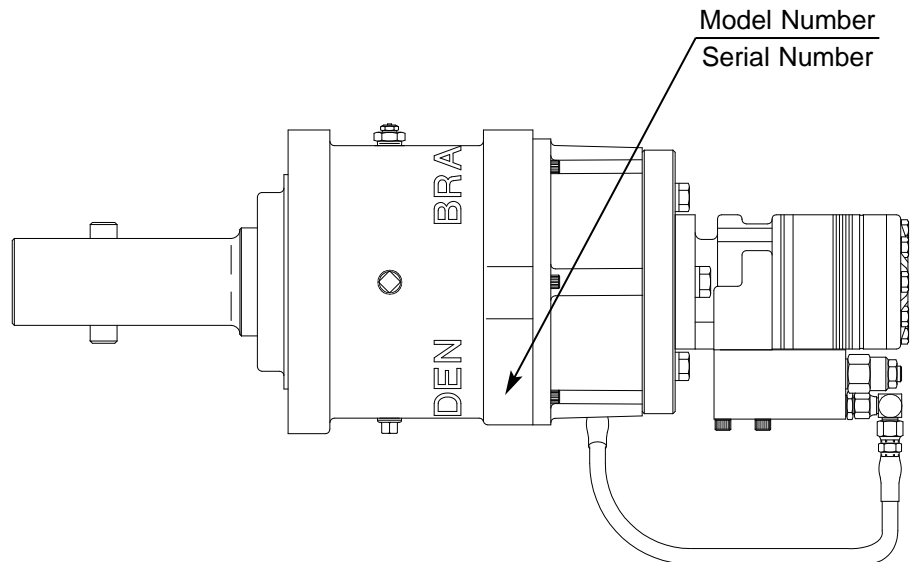

EXPLANATION OF MODEL NUMBER

PCD - 24B - 08 - 071 - 01 - H

- PCD** Designates Planetary Capstan Drive
- 24** Designates Maximum Output Torque (24,000 lb-in.)
- B** Designates Model Series Relating to Design Changes
- 08** Designates Overall Gear Ratio (7.75:1)
- 071** Designates Motor Displacement in cu in./rev (071 = 7.1)
- 01** Designates Output Shaft Configuration (01 = bayonet capstan mounting; 03 = fixed capstan)
- H** Designates High Capacity Option

GENERAL SAFETY RECOMMENDATIONS

Safety for operators and ground personnel is of prime concern. Always take the necessary precautions to ensure safety to others as well as yourself. To ensure safety, the prime mover and drive must be operated with care and concern by the operator for the equipment, and a thorough knowledge of the machine's performance capabilities. The following recommendations are offered as a general safety guide. Local rules and regulations will also apply.

⚠ WARNING ⚠

FAILURE TO OBEY THE FOLLOWING SAFETY RECOMMENDATIONS MAY RESULT IN PROPERTY DAMAGE, PERSONAL INJURY OR DEATH.

1. Read all warning tag information and become familiar with all controls before operating winch.
2. Never attempt to clean, oil or perform any maintenance on a machine with the engine running, unless instructed to do so in the service manual.
3. Never operate drive controls unless you are properly positioned at the operators station on the prime mover and you are sure personnel are clear of the work area.
4. Assure that personnel who are responsible for hand signals are clearly visible and that the signals to be used are thoroughly understood by everyone.
5. Ground personnel should stay in view of the prime mover operator and clear of capstan. Do not allow ground personnel near capstan line under tension. A safe distance of at least 1½ times the length of the rope should be maintained.
6. On machines having hydraulically, mechanically and/or cable controlled equipment, be certain the equipment is either lowered to the ground or blocked securely before servicing, adjusting and/or repairing the drive. Always apply the prime mover parking brakes and lower equipment before dismantling the prime mover.
7. Inspect rigging, drive and hydraulic hoses at the beginning of each work shift. Defects should be corrected immediately.
8. Keep equipment in good operating condition. Perform scheduled servicing and adjustments listed in the "Preventive Maintenance" section of this manual.
9. An equipment warm-up procedure is recommended for all start-ups and is essential at ambient temperatures below +40° F (4° C). Refer to "Warm-up) Procedure" listed in the "Preventive Maintenance" section of this manual.
10. Be sure of equipment stability before operating drive.

11. The drives described herein are neither designed nor intended for use or application to equipment used in the lifting or moving of persons.
12. Do not exceed the maximum pressure (PSI or kPa) or flow (GPM or LPM) stated in the drive specifications.
13. Operate capstan line speeds to match job conditions.
14. Leather gloves should be used when handling rope.
15. Never use rope with broken strands. Replace rope.
16. Do not weld on any part of the drive.
17. Use recommended hydraulic oil and gear lubricant.
18. Keep hydraulic system clean and free from contamination at all times.

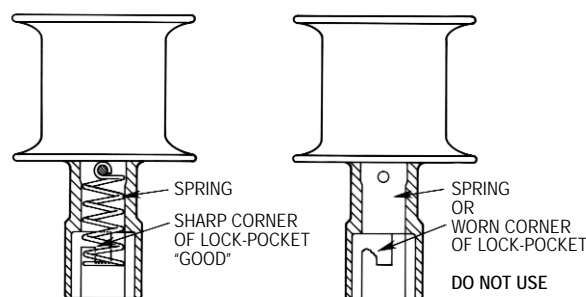

19. Periodically inspect the overall condition of the capstan, paying particular attention to the sharp corner of the lock-pocket as shown above. DO NOT use capstans with a worn lock-pocket or missing spring.
20. Spool the free end of the rope neatly on the ground, avoiding the rope becoming tangled around your feet and/or legs.
21. If the original capstan pin is replaced with a bolt, it MUST be a grade 8 with a self-locking nut.
22. Load ratings or line pulls of capstan drives are dependent on the motor used and whether or not the unit has the high capacity option. Be sure the load you intend to place on the capstan is within the rating of your particular unit. Refer to publication PB-215 for unit ratings.
23. Install guarding to prevent personnel from getting any part of body or clothing caught at a point where the rope is wound onto the capstan. Appropriate guards should be installed around exposed portions of the capstan shaft.
24. Install switches or valves which will shut off power to the winch in locations where they can be reached by anyone entangled in the rope before being drawn onto the capstan or any "pinch point".
25. "Deadman" controls, which automatically shut off power to the capstan drive whenever the operator leaves his station, should be installed whenever possible.

Safety Information continued next page.

- 26. Never allow anyone to stand under a suspended load.
- 27. Exposed areas of capstan shafts are dangerous. Clothing and other items may become tangled and wrapped around the shaft when rotating. Appropriate

guarding should be installed to prevent any part of the body or clothing from contacting the shaft when it is rotating. Failure to provide appropriate guarding could result in property damage, injury or death.

Safety information callouts used in this manual:

⚠ WARNING ⚠

WARNING: This emblem is used to warn against hazards and unsafe practices which could result in severe personal injury or death if proper procedures are not followed.

⚠ CAUTION ⚠

CAUTION: This emblem is used to warn against potential or unsafe practices which could result in personal injury or product or property damage if proper procedures are not followed.

THEORY OF OPERATION

The PCD24B capstan drive is made up of the following sub-assemblies and parts:

1. Hydraulic motor and brake valve block with cartridges.
2. Static brake assembly.
3. Planetary gear set.
4. Output shaft and bearings.

The static brake assembly is a multiple disk pack which is spring applied, hydraulically released, and equipped with a solid hub coupling the motor shaft to the planetary sun gear. This means that the static brake is applied when the drive is stopped, keeping the output shaft from rotating in either direction. Also, the motor cannot operate the drive in either direction until the brake has been released.

In operation, the static brake must be hydraulically released when the drive is operated in either direction.

When the control valve handle is moved in either direction, hydraulic pressure is piloted to the brake release piston and routed to the motor at the same time. Oil flow out of the motor is initially blocked by one of the counterbalance cartridges. As hydraulic pressure increases, the static brake is released. At this time, oil flow out of the motor is still blocked. As pressure continues to increase, the cartridge is piloted open and the motor is allowed to turn. This sequence ensures the static brake is completely released before any rotation occurs, resulting in minimal wear of the friction disks in the brake assembly. The extent to which the cartridge opens will determine the amount of oil that can flow through it and the speed of the output shaft. Increasing the flow of oil to the drive will cause the pressure to rise and the opening in the cartridge to enlarge, allowing more oil to flow and increasing the speed of the output shaft. Decreasing this flow causes the pressure to lower, decreasing the opening in the cartridge and slowing down the output shaft. When the control valve is returned to center and oil flow is stopped, motor rotation stops and the static brake is fully applied by the brake springs.

Disc brake (static parking brake) releases at approx. 390 psi (2,690 kPa) at no load.

Dual cartridge counterbalance valve opens at approx. 960 psi (6,620 kPa) at 15 gmp (57 Lpm).

Dual cartridge counterbalance valve opens at approx. 1,580 psi (10,890 kPa) at 30 gpm (114 Lpm).

NOTE: Pressures shown above are ΔP across the motor.

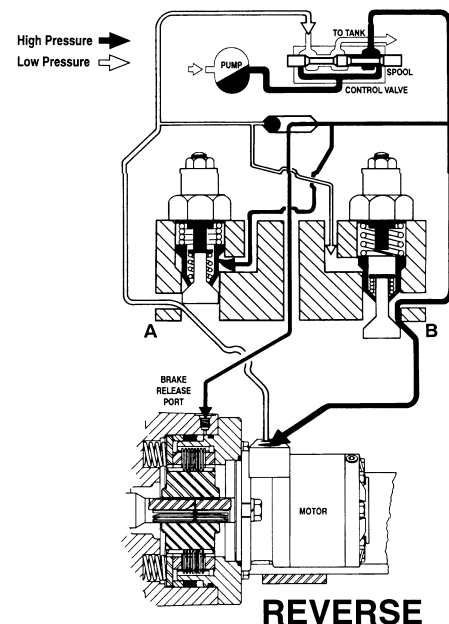
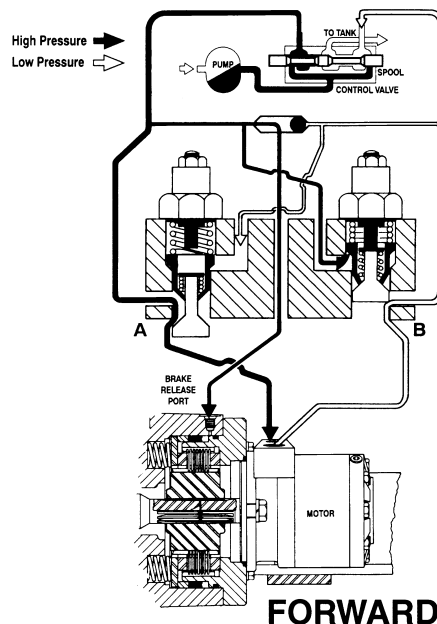

DRIVE INSTALLATION

The PCD24B capstan drive should normally be mounted with the centerline of the output shaft in a horizontal position. The drive may be rotated to any position around this centerline. There are four $\frac{3}{8}$ NPT plugs in the drive housing, 90 degrees apart. When the mounting position of the drive is determined, the highest of these plugs should be removed and replaced with the reducer bushing and vent plug, which are shipped with the drive. The drive is shipped with oil, so be sure the plug you remove is above the horizontal centerline to avoid oil loss.

The drive housing has six (6) through drilled holes for $\frac{5}{8}$ in. capscrews and four (4) holes drilled and tapped to $\frac{3}{4}$ - 10 that can be used for mounting. The drive can be either flange mounted using the four holes in the face of the housing, or surface mounted using the four tapped holes. A minimum of four (4) grade 5 or better fasteners should be used.

Both motor ports on all drives are SAE -10 ORB, and are located in the brake valve block. The shift port on two speed motors is SAE -4 ORB, also in the valve block. Two speed motors normally operate in low speed, and are shifted to high speed by applying a minimum of 100 PSI to the shift port. Shift pressure MUST be 100 PSI greater than the return line back pressure, and can be as high as system pressure. The shift port is shown as port "X" in the hydraulic circuit drawing that follows.

The hydraulic lines and components that operate the drive should be of sufficient size to assure minimum back pressure at the motor. Back pressure at the motor must not exceed 100 PSI (690 kPa) to maintain optimum motor seal life and assure complete brake application.

The directional control valve must be a three position four way valve with a motor spool such that when the valve is in the center position both work ports are open to tank (open center, open port).

To install the bayonet type capstan, push the capstan

onto the extension shaft, against spring tension, then turn counter-clockwise (viewed from the outside) to the stop. Release the capstan and verify that the spring has pushed the capstan outward into the lock position. A cutaway drawing of the capstan is shown in the "General Safety Recommendations" earlier in this manual.

High quality hydraulic oil is essential for satisfactory performance and long hydraulic system component life. Oil having 150 to 330 SUS viscosity at 100° F (38° C) and viscosity index of 100 or greater will give good results under normal temperature conditions. The use of an oil having a high viscosity index will minimize cold start trouble and reduce the length of warm-up periods. A high viscosity index will minimize changes in viscosity with corresponding changes in temperature.

Maximum cold weather start-up viscosity should not exceed 5,000 SUS with a pour point at least 20° F (11° C) lower than the minimum ambient temperature.

Under continuous operating conditions the temperature of the oil at any point in the system must not exceed 180° F (82° C).

120° F (49° C) to 140° F (60° C) is generally considered optimum.

In general terms:

For continuous operation at ambient temperatures between 50° F (10° C) and 110° F (43° C), use SAE 20W

For continuous operation between 10° F (-12° C) and 90° F (32° C), use 10W

For applications colder than 10° F (-12° C), contact the Braden Service Department.

The use of multi-viscosity oils is generally not recommended.

The hydraulic oil filter should have a 10 micron nominal rating and be full flow type.

TYPICAL INSTALLATION DIMENSION DRAWINGS

Mounting dimensions for all units are the same. Drive shown below has the 088 motor option. Consult publication PB-215 for other motor dimensions and performance data.

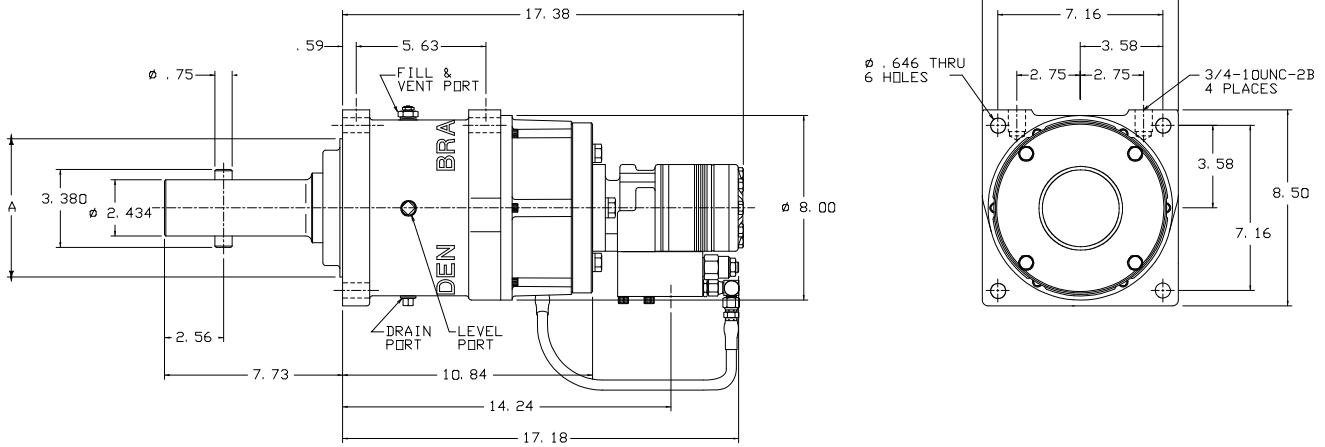

	Dimension A
Standard Unit	4.75 in. diam.
High Capacity Option	6.00 in. diam.

HYDRAULIC CIRCUITS

DRIVE CONTROL CIRCUIT SINGLE SPEED MOTOR

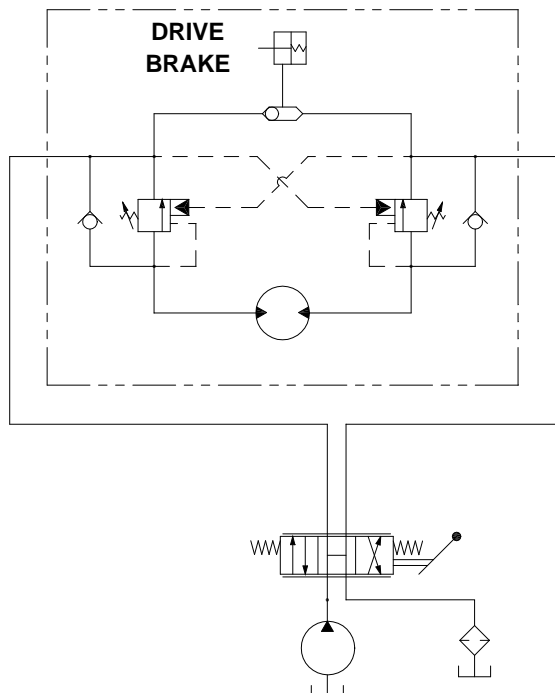

DRIVE CONTROL CIRCUIT 2-SPEED MOTOR

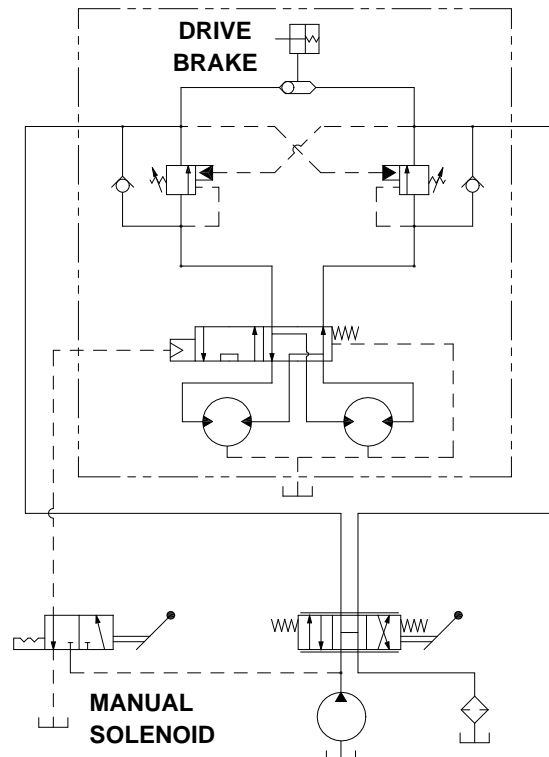

PREVENTIVE MAINTENANCE

A regular program of preventive maintenance for your planetary capstan drive is strongly recommended to minimize the need for emergency servicing and promote safe, reliable operation.

Field experience supported by engineering tests, indicates the two service procedures listed below are the **MOST** critical to safe, reliable operation and must be observed.

Regular Gear Oil Changes – every 1,000 hours or six (6) months.

Use of Proper Gear Oil – recommended type for prevailing ambient temperature.

The following minimum service intervals are specified for operating hours of the prime mover.

1. Oil Level

The gear oil level should be checked every 500 hours of operation or three (3) months, whichever occurs first, or whenever there is any sign of oil leakage. Oil level should be even with the centerline of output shaft. Typically, one of the four plugs in the housing will be on the drive centerline and can be used to check oil level. The oil level should be even with the bottom of the plug opening. If additional oil is needed, refer to "Recommended Gear Oil".

2. Oil Change

The gear oil should be changed after the first one hundred (100) hours of operation, then every 1,000 operating hours or six (6) months, whichever occurs first. The gear oil must be changed to remove wear particles that impede the safe and reliable

operation of the brake and erode bearings, gears and seals. Failure to change gear oil at these suggested minimum intervals may contribute to intermittent brake slippage which could result in property damage, severe personal injury or death.

Remove the drain plug from the housing and drain the oil into a suitable container. Capacity of the unit is 2 pints (0.95 L). Remove the vent plug from the housing. It is very important to keep this vent clean and unobstructed. Clean the vent in solvent, be sure it is not plugged, and re-install it in the drive. Do not paint over the vent or replace it with a solid plug.

3. Hydraulic System

The original filter element should be replaced after the first fifty (50) hours of operation, then every 500 operating hours or three (3) months, or in accordance with the equipment manufacturer's recommendations.

4. Mounting Bolts

Tighten all capstan drive mounting bolts to recommended torque after the first one hundred (100) hours of operation, then every 1,000 operating hours or six (6) months, whichever occurs first.

5. Warm-up Procedure

A warm-up procedure is recommended at each start-up and is essential at ambient temperatures below 40° F (4° C).

The prime mover should be run at its lowest recommended RPM with the capstan drive control lever in neutral allowing sufficient time to warm up the hydraulic system. The drive should be operated at low speeds, forward and reverse, several times to prime all lines with warm hydraulic oil, and to circulate gear lubricant through the planetary gears and bearings.

⚠ WARNING ⚠

The brake valve cartridges are factory set and normally require no further adjustment. The brake valve can be manually piloted open by its adjusting screw. Manually opening brake valve could cause internal drive damage and may cause loss of load control during lowering operations which may result in property damage, severe injury or death.

The brake valve cartridges may be unique in that turning the adjustment screw in, clockwise, lowers the brake release pressure. In the event it has been determined a brake valve adjustment is required the entire brake valve cartridge should be replaced.

The brake valve cartridge is easily removed from the brake valve block for cleaning, inspection or replacement, but is not designed to be disassembled in the field. In the event it has been determined the brake valve should be disassembled, the entire brake valve cartridge should be replaced.

RECOMMENDED PLANETARY GEAR OIL

Field experience, supported by engineering endurance tests, indicates the use of the proper gear oil and a program of regular preventive maintenance will help provide extended gear train life and reliable winch brake performance. For this reason, BRADEN has published the following specifications to assist in determining which lubricant is best suited to your application.

⚠ WARNING ⚠

Failure to properly warm up the capstan drive, particularly under low ambient temperature conditions, may result in temporary brake slippage due to high back pressures attempting to release the brake, which could result in property damage, severe personal injury or death.

⚠ WARNING ⚠

Failure to use the proper type and viscosity of planetary gear oil may contribute to intermittent brake clutch slippage which could result in property damage, severe personal injury or death. Some gear lubricants contain large amounts of EP (extreme pressure) and anti-friction additives which may contribute to brake clutch slippage or damage to brake friction discs or seals. Oil viscosity with regard to ambient temperature is also critical to reliable brake clutch operation. Our tests indicate that excessively heavy or thick gear oil may contribute to intermittent brake clutch slippage. Make certain that the gear oil viscosity used in your winch is correct for your prevailing ambient temperature.

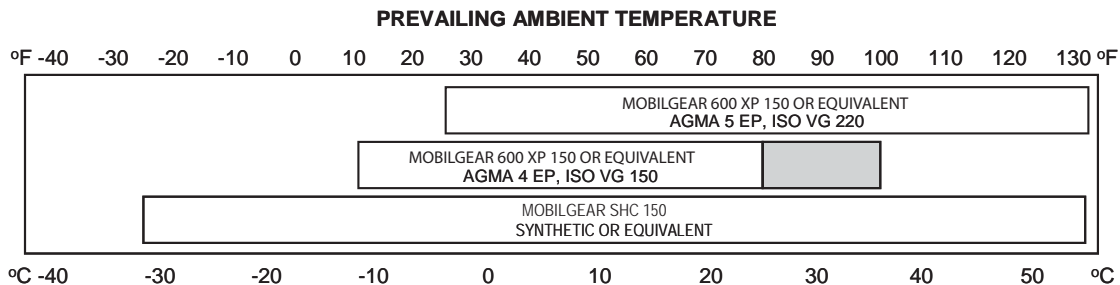

i NOTE: SHADED TEMPERATURE RANGE IN THE CHART ABOVE NOT RECOMMENDED FOR SEVERE APPLICATIONS SUCH AS: OFFSHORE CRANES, SUSTAINED FAST DUTY CYCLES OR FREQUENT LIFTING.

Planetary hoists are factory filled with Mobilgear 600 XP 150, or equivalent. Consult your oil supplier for other equivalent oils if required.

Mobil	Shell	Chevron	Texaco
Mobilgear 600 XP 150	Omala 150	Gear Compounds EP 150	Meropa 150
Mobilgear 600 XP 220	Omala 220	Gear Compounds EP 220	Meropa 220

Unless otherwise specified, it is recommended that the gear oil be changed after the first one hundred (100) hours or thirty (30) days of machine operation, then every one thousand (1,000) hours or twelve (12) months, whichever occurs first. The gear oil should also be changed whenever the ambient temperature changes significantly and an oil from a different temperature range would be more appropriate.

UNIT WEIGHTS

Drive Configuration	Weight (lbs)	Weight (kg)	Drive Configuration	Weight (lbs)	Weight (kg)
049 motor	152	69	088 motor	146	66
071 motor	152	69	088 motor (fixed capstan)	195	88
080 motor	154	70	119 motor	158	72
			129 motor	154	70
			072/036 (2 speed motor)	170	77

TROUBLE SHOOTING

TROUBLE A: CAPSTAN DRIVE WILL NOT PULL MAXIMUM LOAD.

PROBABLE CAUSE	REMEDY
1. System relief valve may be set too low	Install a pressure gauge in the haul-in port and apply a stall pull on the capstan. If pressure is low, increase relief valve setting until recommended pressure is obtained. NOTE: If pressure does not increase in proportion to adjustment, relief valve may be contaminated or worn out. In either case, the relief valve may require disassembly or replacement.
2. If this trouble occurs suddenly after working at maximum pull, a particle of dirt may be lodged under the system relief valve, holding it partially open. If this is the cause, a considerable loss in line speed may be noticed as the load on the rope is increased.	Remove relief valve, disassemble and clean parts thoroughly in a suitable solvent. Reassemble and install relief valve. Reset pressure according to specifications.
3. If the pump is belt driven, the belts may be slipping.	Check belts when pump is at full PSI (kPa) (stall pull on capstan). Tighten belts if they are found to be slipping.
4. The oil level in the reservoir may be too low. The suction line may be restricted or have an air leak causing cavitation at the inlet port. This will cause the pump to make a whining noise.	Check oil level in the reservoir. Check the suction line for damage, externally and internally. Replace suction line if necessary.
5. The drive may be mounted on an uneven or flexible surface which causes distortion of the base and binding of the gear train. Binding in the gear train will absorb horsepower needed to generate the rated line pull and cause heat.	Reinforce mounting surface. If necessary, use steel shim stock to level the drive. First loosen, then evenly retighten all drive mounting bolts to recommended torque.
6. Be certain hydraulic system temperature is not more than 180° F (82° C). Excessive hydraulic oil temperatures increase motor internal leakage and reduce motor performance.	Same as remedy for A-5. same as remedy for B-4.
7. After all the causes listed above have been investigated and it is found that the drive will stall at maximum pressure without developing the maximum pull on the capstan, the trouble may be in the drive.	Install a pressure gauge in the motor haul-in port and apply a stall pull on the capstan. If the pressure is up to maximum and the line pull is less than the specified line pull, the trouble will be in the drive. Disassemble drive according to disassembly instructions and check that gear train turns freely. If gear train is found to be satisfactory, inspect the hydraulic motor, according to the service instructions for the hydraulic motor.

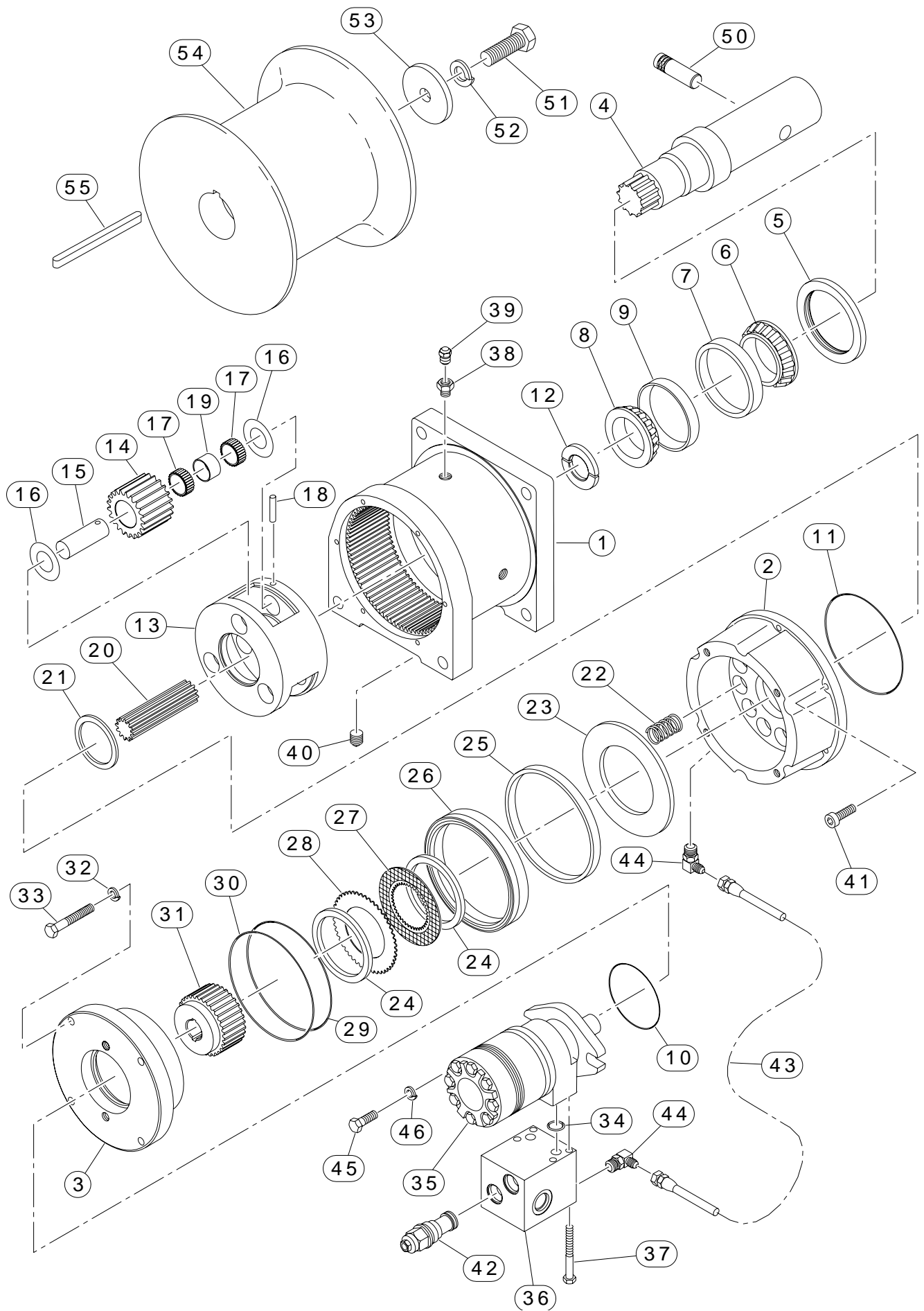

PCD24B PARTS KEY

ITEM	DESCRIPTION	QTY.
1	HOUSING	1
2	BRAKE CYLINDER	1
3	MOTOR SUPPORT	1
4	OUTPUT SHAFT	1
5	SEAL	1
6	TAPERED BEARING CONE	1
7	TAPERED BEARING CUP	1
8	TAPERED BEARING CONE	1
9	TAPERED BEARING CUP	1
10	O-RING OR GASKET (depending on motor option)	1
11	O-RING	1
12	SPLIT RING	1
13	PLANET CARRIER	1
14	PLANET GEAR	3
15	PLANET GEAR SHAFT	3
16	THRUST RACE	6
17	ROLLER BEARING	6
18	ROLLPIN	3
19	BEARING SPACER	3
20	SUN GEAR	1
21	THRUST WASHER	1
22	SPRING	12
23	PRESSURE PLATE	1
24	SPACER PLATE	2
25	BRAKE PISTON	1
26	BRAKE PISTON SEAL	1
27	FRICTION DISC	7
28	STEEL DISC	8
29	O-RING	1
30	BACKUP RING	1
31	BRAKE COUPLING	1
32	LOCKWASHER	4
33	CAPSCREW (HEX HEAD)	4
34	O-RING	2
35	MOTOR	1
36	BRAKE VALVE BLOCK	1
37	CAPSCREW	4
38	REDUCER BUSHING	1
39	VENT PLUG	1
40	PIPE PLUG	4
41	CAPSCREW (SOCKET HEAD)	6
42	COUNTERBALANCE VALVE CARTRIDGE	2
43	HOSE ASSEMBLY	1
44	ELBOW FITTING	1
45	CAPSCREW	2
46	LOCKWASHER	2
47	ELBOW FITTING	1
50	CAPSTAN PIN (not used with fixed capstan)	1
51	CAPSCREW (HEX HEAD - fixed capstan ONLY)	1
52	LOCKWASHER (fixed capstan ONLY)	1
53	WASHER (fixed capstan ONLY)	1
54	CAPSTAN (fixed capstan ONLY)	1
55	KEY (fixed capstan ONLY)	1

For part numbers, refer to PCD-24B Material List,
Publication Number PB-244.

Trouble Shooting Continued

TROUBLE B: CONSIDERABLE REDUCTION IN LINE SPEED.

PROBABLE CAUSE	REMEDY
1. Same as A-2.	Same as remedy for A-2.
2. Same as A-4.	Same as remedy for A-4.
3. Same as A-6.	Same as remedy for A-5 and B-4.
4. If this trouble has increased gradually, the hydraulic pump or drive motor may be worn.	Remove and inspect pump. If satisfactory, consult the disassembly instructions for the drive and remove and inspect the motor according to the service instructions for the hydraulic motor.

TROUBLE C: BRAKE WILL NOT HOLD WHEN CONTROL VALVE IS RETURNED TO NEUTRAL AFTER LIFTING A LOAD.

PROBABLE CAUSE	REMEDY
1. Excessive system back pressure acting on the brake release port.	Install a pressure gauge at the "pay-out" port of the hydraulic motor. Operate the pump at full throttle and monitor pressure in "neutral" and haul-in positions. If the pressure is greater than 50 PSI, check for restrictions in the return line from the winch to the control valve and the control valve to the reservoir.
2. Friction brake will not hold due to worn or damaged brake disks.	Disassemble drive to inspect/replace worn parts.

TROUBLE D: THE CAPSTAN WILL NOT LOWER THE LOAD OR NOT LOWER THE LOAD SMOOTHLY.

PROBABLE CAUSE	REMEDY
1. The friction brake may not be releasing as a result of a defective brake cylinder seal. NOTE: If the brake cylinder seal is defective you will usually notice oil leaking from the drive vent plug.	Disassemble and inspect the brake cylinder seal.
2. Friction brake will not release as a result of damaged brake disks.	Disassemble brake to inspect brake disks.
3. Same as B-4.	Same as remedy for B-4.
3. Same as A-3.	Same as remedy for A-3.
4. Same as A-5.	Same as remedy for A-5.

**TROUBLE D continued:
THE CAPSTAN WILL NOT LOWER THE LOAD OR
NOT LOWER THE LOAD SMOOTHLY.**

PROBABLE CAUSE	REMEDY
6. Control valve handle being operated too quickly.	Operate control valve smoothly when starting and stopping a load. Conduct operator training as required.
7. Insufficient gear oil in drive.	Remove oil level plug and check oil level. Fill to proper level.
8. Control valve does not have good metering characteristics.	See "Drive Installation" section for control valve specifications.

**TROUBLE E:
THE DRIVE RUNS HOT.**

PROBABLE CAUSE	REMEDY
1. Same as A-5.	Same as remedy for A-5.
2. Be certain that the hydraulic system temperature is not more than 180° F (82° C). Excessive hydraulic oil temperatures may be caused by:	
A. Plugged heat exchanger.	Thoroughly clean exterior and flush interior.
B. Too low or too high oil level in hydraulic reservoir.	Fill/drain to proper level.
C. Same as A-1.	Same as remedy for A-1.
D. Hydraulic pump not operating efficiently.	Remove and inspect pump. Check suction line for damage. If pump is belt driven, belts may be slipping. Replace/tighten belts.
3. Excessively worn or damaged internal drive parts.	Disassemble drive to inspect/replace worn parts.
2. Same as D-7.	Same as remedy for D-7.

**TROUBLE F:
DRIVE "CHATTERS" WHILE RAISING RATED LOAD.**

PROBABLE CAUSE	REMEDY
1. Same as A-1.	Same as remedy for A-1.
2. Same as B-4.	Same as remedy for B-4.
3. Hydraulic oil flow to motor may be too low.	Increase pump rpm.
4. Same as D-6.	Same as remedy for D-6.

CAPSTAN DRIVE SERVICE

Foreword to Drive Service

Before any part is removed from the capstan drive, all service instructions should be read and understood.

Work in a clean, dust free area as cleanliness is of utmost importance when servicing hydraulic equipment.

Inspect all replacement parts prior to installation to detect any damage which might have occurred in shipment.

Use only genuine BRADEN replacement parts for optimum results. Never reuse expendable parts such as oil seals and O-rings.

Inspect all machined surfaces for excessive wear or damage before beginning to reassemble the drive.

Lubricate all O-rings and oil seals with gear oil prior to installation.

Use a non-hardening sealing compound on the outside surface of oil seals and a light coat of thread sealing compound on pipe threads. Avoid getting thread compound inside parts or passages that conduct oil.

Thoroughly clean all parts in a good grade of non-flammable safety solvent. Wear protective clothing as required.

Refer to exploded view drawing in the center of this manual for item numbers used in service procedures.

⚠ WARNING ⚠

DO NOT CLEAN BRAKE FRICTION DISCS IN SOLVENT. SOLVENT MAY CAUSE DAMAGE TO FRICTION MATERIAL WHICH MAY RESULT IN BRAKE FAILURE AND LOSS OF LOAD CONTROL.

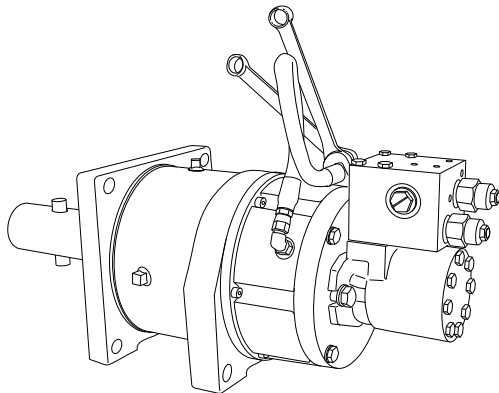

DRIVE DISASSEMBLY

1. Disconnect and remove the hose (item 43) between the brake valve block and the brake cylinder. Remove the two capscrews holding the motor to the motor support and remove the motor. Remove and discard the motor pilot O-ring. Remove one of the oil drain plugs (item 40) and drain the gear oil into a suitable container.

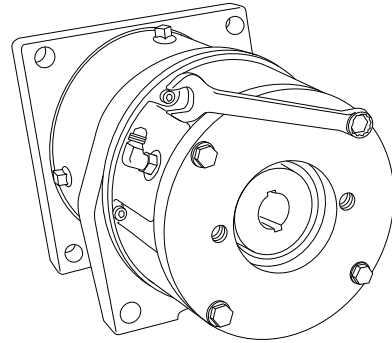

2. The four capscrews holding the motor support to the brake cylinder should be evenly removed in 1 or 2 turn increments since the motor adapter is under spring tension. Mark the relative position of the motor support to the brake cylinder. This will assure the motor will be correctly positioned when the unit is re-assembled.

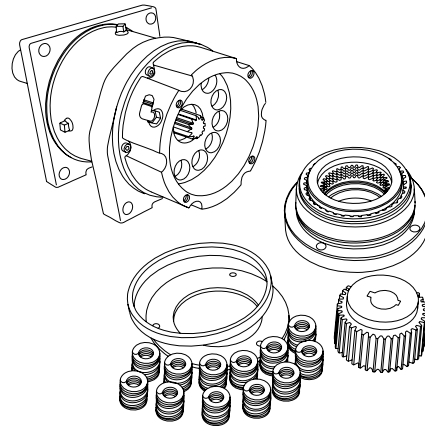

3. Remove the motor support, complete static brake assembly, brake coupling (item 31) and all other parts inside the brake cylinder (item 2). Remove and discard the O-ring and backup ring (items 29 & 30) and the brake piston seal (item 26).

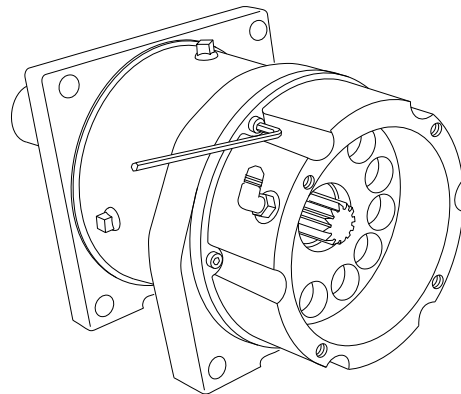

4. Remove the six (6) capscrews holding the brake cylinder to the main housing (item 1). Mark the relative position of the brake cylinder to the main housing. This will assure the brake release port will be correctly positioned when the unit is re-assembled.

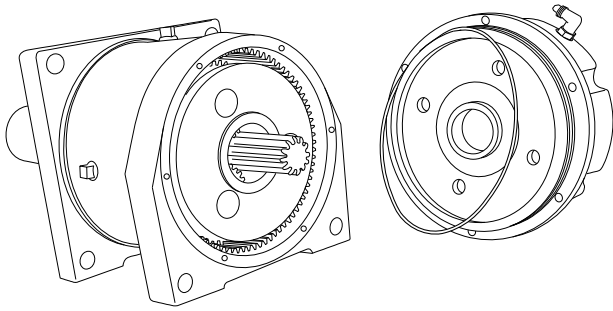

5. Separate the brake cylinder from the main housing and remove and discard the O-ring from the brake cylinder.

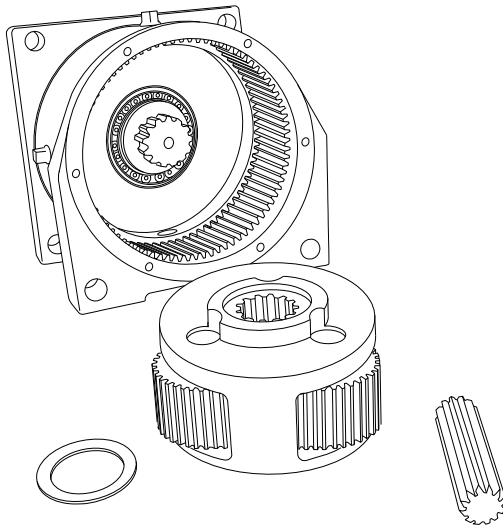

6. Remove the sun gear (item 20) and the planetary carrier assembly. Keep the thrust washer (item 21) with the planetary carrier for inspection when the gear set is serviced.

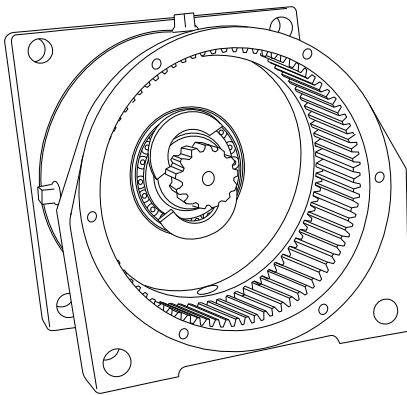

7. Separate and remove the two halves of the split ring (item 12). Support the main housing as shown above and press out the output shaft (item 4). The two tapered roller bearing cups and cones (items 6, 7, 8, & 9) can now be removed from the housing and output shaft. Remove the seal (item 5) from the main housing. Remove the vent plug (item 39) from the housing, clean in solvent and reinstall. DO NOT paint over the vent or

replace it with a solid plug. If one of the oil drain plugs was removed, clean the plug and hole, apply a light coat of thread sealing compound to the plug and re-install it into the housing. Thoroughly clean and inspect the housing for damage. Check the ring gear teeth (machined into the inside of the housing) for nicks, spalling or excessive wear. Replace the housing if gear tooth wear is greater than 0.015 in. (0.4 mm) when compared to unworn area of teeth.

This completes disassembly of the capstan drive.

PLANET CARRIER SERVICE

Disassembly

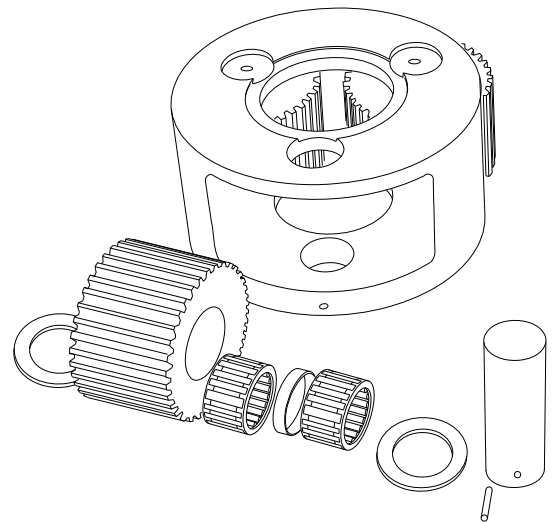

1. Each planet gear is removed by first driving the rollpin (item 18) into the planet gear shaft (item 15). The planet gear shaft can then be pushed through the planet carrier (item 13). Drive the rollpin out of the shaft and discard. Remove the planet gear (item 14) and two thrust races (item 16). The two roller bearings (item 17) and bearing spacer (item 19) are then removed from the planet gear.

Repeat this procedure for each of the other two gears.

Thoroughly clean all parts and inspect for damage and wear. The bearing rollers should not exhibit any irregularities. If the rollers show any sign of spalling, corrosion, discoloration, material displacement or abnormal wear, the bearing should be replaced. Likewise, the cage should be inspected for unusual wear or deformation, particularly the cage bars. If there is any damage that will impair the cage's ability to separate, retain and guide the rollers properly, the bearing should be replaced. The thrust washer contact areas should be free from any surface irregularities that may cause abrasions or friction. The gears and shafts should be inspected for abnormal wear or pitting and replaced if necessary.

Assembly

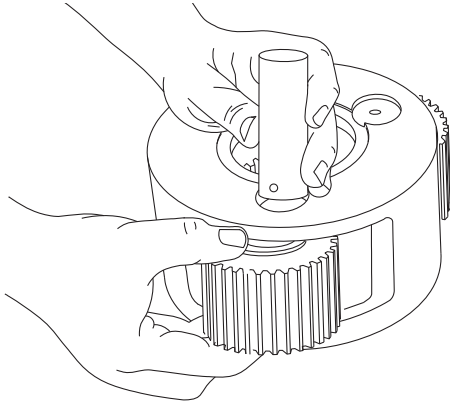

1. Insert two bearings with a spacer between them into a planet gear. Place a thrust race on each side of the gear and position this assembly in the planet carrier. Slide the planet gear shaft through the carrier and gear assembly, aligning the pin hole in the shaft with the hole in the carrier.

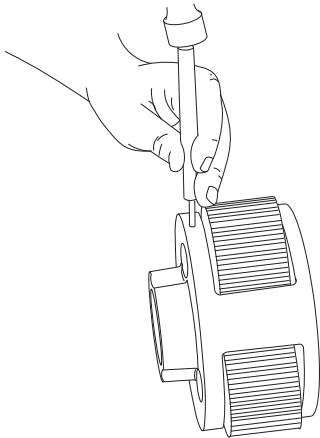

2. Drive a NEW rollpin into place. **Always use NEW rollpins.** When properly positioned, 50% of the rollpin length should be engaged in the planet gear shaft with the remaining 50% in the carrier.

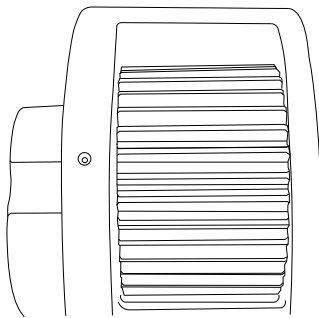

3. With a center punch, stake the carrier next to the pin hole. This will distort the hole in the carrier so the rollpin will not back out when in service. Repeat steps 1 through 3 for each of the other two gears.

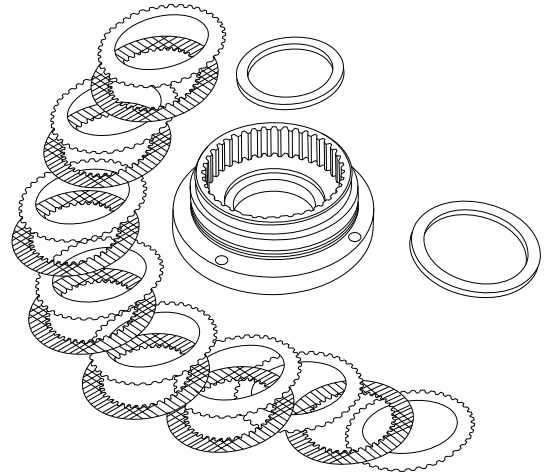

STATIC BRAKE SERVICE

1. Remove all friction and steel discs (items 27 & 28) and both spacer plates (item 24) from the motor adapter.

⚠ WARNING ⚠

DO NOT CLEAN BRAKE FRICTION DISCS IN SOLVENT. SOLVENT MAY CAUSE DAMAGE TO FRICTION MATERIAL WHICH MAY RESULT IN BRAKE FAILURE AND LOSS OF LOAD CONTROL.

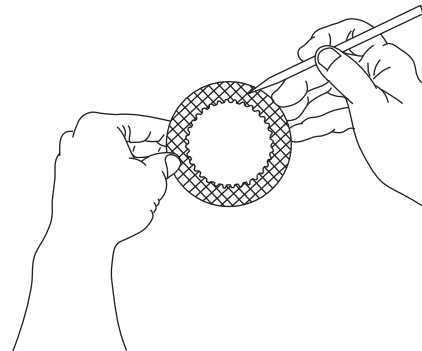

1. Thoroughly clean and inspect all parts at this time. Check brake piston sealing surfaces on motor adapter and brake cylinder (item 2) for damage or excessive wear. Be sure the brake release port in the brake cylinder is open and free of contamination.

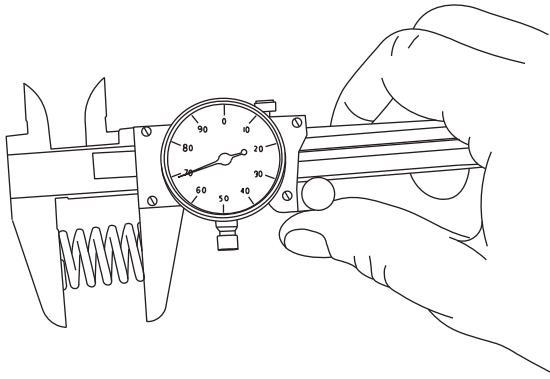

2. Place each friction disc on a flat surface and check for distortion with a straight edge. Friction material should appear even across entire surface with groove pattern visible. Replace friction disc if splines are worn to a point, disc is distorted, friction material is worn unevenly, groove pattern is worn away or friction material is burned. Place each steel disc on a flat surface and check for distortion with a straight edge. Check surface for signs of material transfer or heat. Replace steel disc if splines are worn to a point, disc is distorted or heat discolored.



3. Check free length of each brake spring. Minimum free length is 15/16 inch (23.8 mm). Check springs for any signs of cracking or failure. If a brake spring must be replaced for any reason, then ALL brake springs must be replaced.

 CAUTION 
<p>FAILURE TO REPLACE BRAKE SPRINGS AS A SET MAY RESULT IN UNEVEN BRAKE APPLICATION PRESSURE AND REPEATED BRAKE SPRING FAILURE.</p>

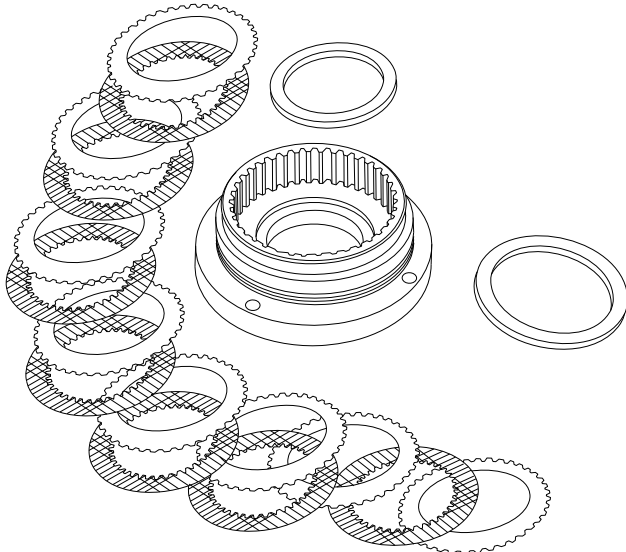

4. Place the motor support on workbench with the motor mounting surface down and install one spacer plate (item 24). Insert a steel disc (item 28) against the spacer plate, followed by a friction disc (item 27). Alternately install steel and friction discs until seven (7) friction discs and eight (8) steel discs have installed, finishing with a steel disc. Install the second spacer plate (item 24) on top of the last steel disc.

NOTE: It is a good practice to lubricate the discs with gear oil prior to installation.

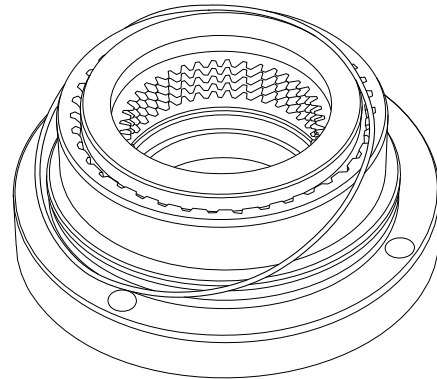

5. Install backup ring (item 30) onto the motor support with the flat side down. Install O-ring (item 29) onto the motor support. The O-ring will fit into the groove in the backup ring.

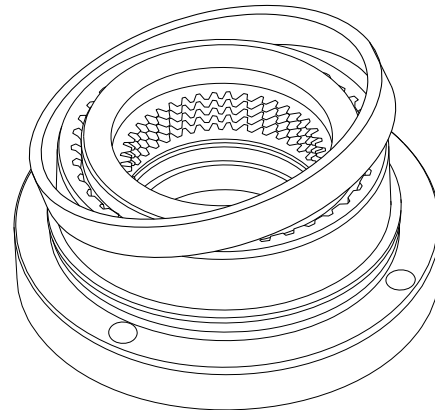

6. Lightly lubricate the brake piston seal with hydraulic oil and install the seal onto the motor support. The seal **MUST** be installed with the wide end down, toward the O-ring installed in the last step.

CAPSTAN DRIVE ASSEMBLY

1. If any of the oil drain plugs or vent was previously removed, install them into the main housing using a non-hardening thread sealing compound. Press bearing cups (items 7 & 9) into the housing. Install the larger bearing cone (item 6) into the cup (item 7). Apply a non-hardening sealant on the outside diameter of the seal (item 5) and press it into the housing (item 1) with the spring side toward the bearing, using a flat plate to avoid distortion. Lightly lubricate the sealing and bearing surfaces of the output shaft and insert the shaft into the housing from the output end, being careful not to damage the seal. Install the smaller bearing cone (item 8) onto the output shaft through the inside of the housing.

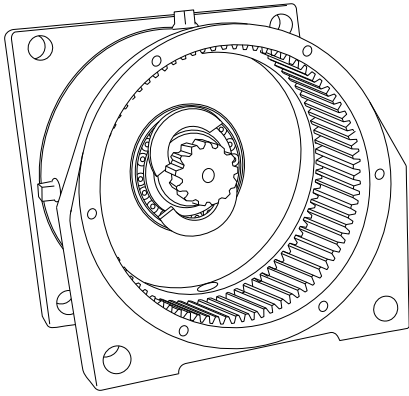

2. Install both halves of the split ring (item 12) around the output shaft and pry firmly into place against the shaft. At this point, the output shaft should rotate smoothly and freely in the housing.

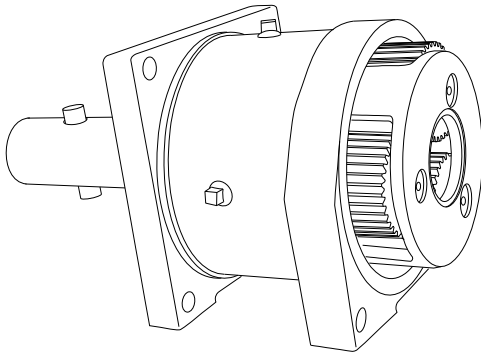

3. Install the planetary gear assembly into the housing. Rotate the planet gears to engage the ring gear and rotate the planet carrier, or the output shaft, to engage the splines on the planet carrier with those on the output shaft. The planet carrier **MUST** fully engage the output shaft and go over the split ring, holding it in place. At this point, the planet carrier will be slightly below the end of the housing. If the planet carrier will not fully drop into the housing, the split ring may not be fully seated against the output shaft. **DO NOT** proceed to the next step until the planet carrier is properly positioned.

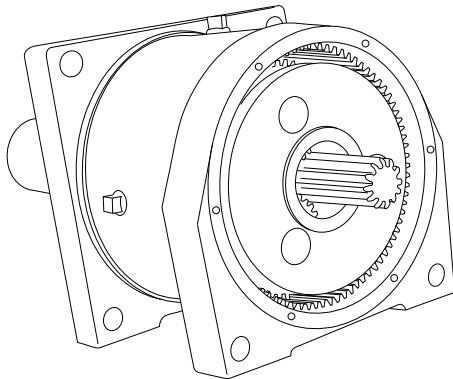

4. Lightly coat the surface of thrust washer (item 21) with an oil soluble grease and position it on the planet carrier. Install the sun gear into the center of the planet gear assembly.

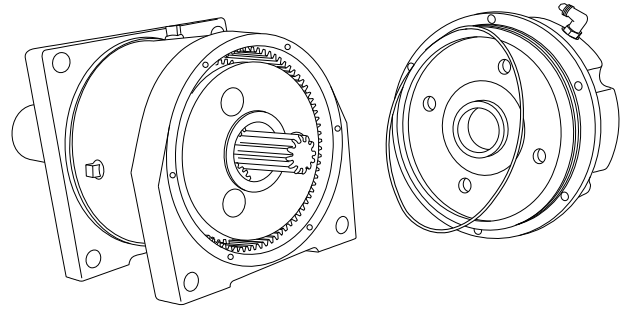

5. Install a new O-ring (item 11) onto the brake cylinder (item 2). Install the brake cylinder onto the main housing, being careful that the thrust washer installed in the previous step stays in position. Make sure the brake release port is properly positioned and install the six (6) socket head capscrews to the proper torque. At this time, the sun gear should turn freely, without any binding of the gear train.

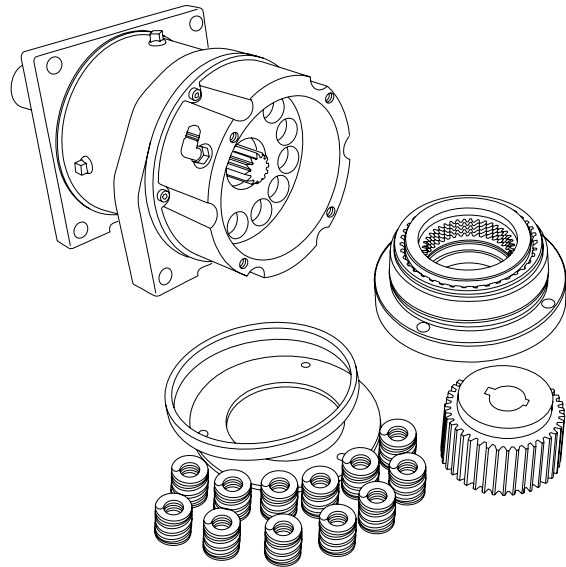

6. Install the twelve (12) springs (item 22) into the spring pockets in the brake cylinder. Set the pressure plate (item 23) onto the springs. Lightly lubricate the brake piston (item 25) with gear oil and install the piston into the brake cylinder. Install the brake coupling (item 31) into the brake discs. The coupling will have to be rotated as it is installed to align the teeth on the friction discs. The stepped end of the coupling, with keyways, faces the motor. Carefully install the motor support/brake assembly into the brake cylinder taking care to not cut the piston seal or O-rings. Be careful the spacer plate (item 24) that rests against the pressure plate remains properly positioned. The brake coupling may have to be rotated slightly to engage the sun gear.

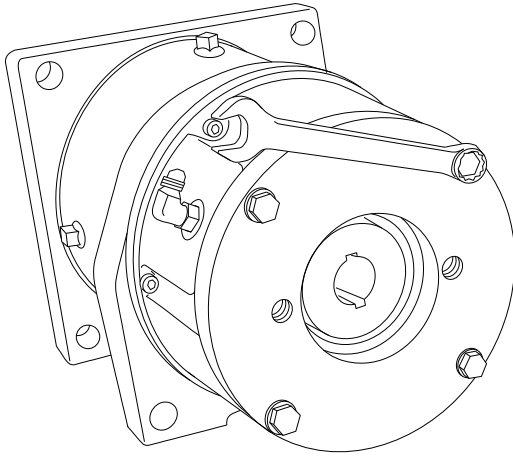

7. Correctly install the motor support onto the brake cylinder and install the four (4) capscrews and lockwashers. These capscrews compress the brake springs and should be tightened evenly in 1 or 2 turn increments until the motor support contacts the brake cylinder. If you encounter excessive resistance that would require more than hand turning of the capscrews, one or more components may have become incorrectly positioned. Remove the motor support and check the position of all parts, especially the spacer plate, and begin the installation again. Tighten all four capscrews to the proper torque.

8. Install a new O-ring (item 10) onto the motor pilot and install the motor onto the motor support with two capscrews and lockwashers (items 45 & 46). Torque the capscrews to their proper value.

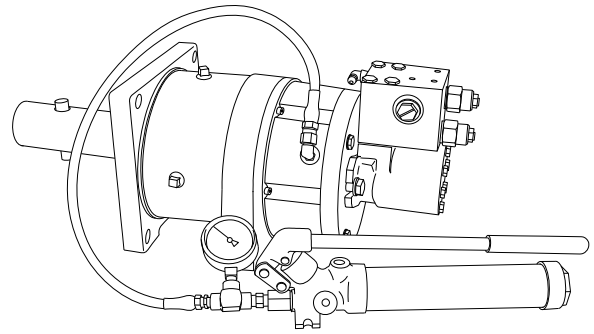

9. Install a hand pump with an accurate 0-2,000 psi (0-13,800 kPa) gauge and shut-off valve to the brake release port. Apply 1,000 psi (6,900 kPa) to the brake and close the shut-off valve. Let the brake stand for five (5) minutes. If there is any loss of pressure, the brake pack should be disassembled for inspection of the sealing surfaces on the brake cylinder and motor support, and for damage to the piston seal or O-ring and backup ring in the motor support. If there is no loss of pressure, release the pressure with the shut-off valve, remove the pump and install the hose between the brake cylinder and the brake valve block.

RECOMMENDED FASTENER TORQUE

The general purpose torque shown in the chart applies to SAE Grade 5 bolts, studs and standard steel full, thick and high nuts.

Higher or lower torques for special applications will be specified such as the use of spanner nuts, nuts on shaft ends, jam nuts and where distortion of parts or gaskets is critical.

Lubricated Torque values based on use of SAE 30wt engine oil applied to threads and face of bolt or nut.

Avoid using thread lubricants as the applied torque may vary by 10-40% depending upon product used.

RECOMMENDED FASTENER TORQUE

Bolt Dia. Inches	Thds Per Inch	Torque (LB-FT)			
		Grade 5		Grade 8	
		Dry	Lubed	Dry	Lubed
1/4	20 28	8	6	12	9
5/16	18 24	17	13	24	18
3/8	16 24	31	23	45	35
7/16	14 20	50	35	70	50
1/2	13 20	75	55	110	80
9/16	12 18	110	80	150	110
5/8	11 18	150	115	210	160

Bolt Dia. Inches	Thds Per Inch	Torque (LB-FT)			
		Grade 5		Grade 8	
		Dry	Lubed	Dry	Lubed
3/4	10 16	265	200	380	280
7/8	9 14	420	325	600	450
1	8 14	640	485	910	680
1 1/8	7 12	790	590	1290	970
1 1/4	7 12	1120	835	1820	1360
1 3/8	6 12	1460	1095	2385	1790
1 1/2	6 12	1940	1460	3160	2370

To convert lb. ft. to kg•m, multiply lb. ft. value by 0.1383.

METRIC CONVERSION TABLE

English to Metric			Metric to English		
LINEAR					
inches (in.)	X 25.4	= millimeters (mm)	millimeters (mm)	X 0.3937	= inches (in.)
feet (ft.)	X 0.3048	= meters (m)	meters (m)	X 3.281	= feet (ft.)
miles (mi.)	X 1.6093	= kilometers (km)	kilometers (km)	X 0.6214	= miles (mi.)
AREA					
inches ² (sq.in.)	X 645.15	= millimeters ² (mm ²)	millimeters ² (mm ²)	X 0.000155	= inches ² (sq.in.)
feet ² (sq.ft.)	X 0.0929	= meters ² (m ²)	meters ² (m ²)	X 10.764	= feet ² (sq.ft.)
VOLUME					
inches ³ (cu.in.)	X 0.01639	= liters (l)	liters (l)	X 61.024	= inches ³ (cu.in.)
quarts (qts.)	X 0.94635	= liters (l)	liters (l)	X 1.0567	= quarts (qts.)
gallons (gal.)	X 3.7854	= liters (l)	liters (l)	X 0.2642	= gallon (gal.)
inches ³ (cu.in.)	X 16.39	= centimeters ³ (cc)	centimeters ³ (cc)	X 0.06102	= inches ³ (cu.in.)
feet ³ (cu.ft.)	X 28.317	= liters (l)	liters (l)	X 0.03531	= feet ³ (cu.ft.)
feet ³ (cu.ft.)	X 0.02832	= meters ³ (m ³)	meters ³ (m ³)	X 35.315	= feet ³ (cu.ft.)
fluid ounce (fl.oz.)	X 29.57	= milliliters (ml)	milliliters (ml)	X 0.03381	= fluid ounce (fl.oz.)
MASS					
ounces (oz.)	X 28.35	= grams (g)	grams (g)	X 0.03527	= ounces (oz.)
pounds (lbs.)	X 0.4536	= kilograms (kg)	kilograms (kg)	X 2.2046	= pounds (lbs.)
tons (2000 lbs.)	X 907.18	= kilograms (kg)	kilograms (kg)	X 0.001102	= tons (2000 lbs.)
tons (2000 lbs.)	X 0.90718	= metric tons (t)	metric tons (t)	X 1.1023	= tons (2000 lbs.)
tons (long) (2240 lbs.)	X 1013.05	= kilograms (kg)	kilograms (kg)	X 0.000984	= tons (long) (2240 lbs.)
PRESSURE					
inches Hg (60°F)	X 3600	= kilopascals (kPa)	kilopascals (kPa)	X 0.2961	= inches Hg (60°F)
pounds/sq.in. (PSI)	X 6.895	= kilopascals (kPa)	kilopascals (kPa)	X 0.145	= pounds/sq.in. (PSI)
pounds/sq.in. (PSI)	X 0.0703	= kilograms/sq.cm. (kg/cm ²)	kilograms/sq.cm. (kg/cm ²)	X 14.22	= pounds/sq.in. (PSI)
pounds/sq.in. (PSI)	X 0.069	= bars	bars	X 14.5	= pounds/sq.in. (PSI)
inches H ₂ O (60°F)	X 0.2488	= kilopascals (kPa)	kilopascals (kPa)	X 4.0193	= inches H ₂ O (60°F)
bars	X 100	= kilopascals (kPa)	kilopascals (kPa)	X 0.01	= bars
POWER					
horsepower (hp)	X 0.746	= kilowatts (kW)	kilowatts (kW)	X 1.34	= horsepower (hp)
ft.-lbs./min.	X 0.0226	= watts (W)	watts (W)	X 44.25	= ft.-lbs./min.
TORQUE					
pound-inches (in.-lbs.)	X 0.11298	= newton-meters (N-m)	newton-meters (N-m)	X 8.851	= pound-inches (in.-lbs.)
pound-feet (ft.-lbs.)	X 1.3558	= newton-meters (N-m)	newton-meters (N-m)	X 0.7376	= pound-feet (ft.-lbs.)
pound-feet (ft.-lbs.)	X .1383	= kilograms/meter (kg-m)	kilogram/meter (kg-m)	X 7.233	= pound-feet (ft.-lbs.)
VELOCITY					
miles/hour (m/h)	X 0.11298	= kilometers/hour (km/hr)	kilometers/hour (km/hr)	X 0.6214	= miles/hour (m/h)
feet/second (ft./sec.)	X 0.3048	= meter/second (m/s)	meters/second (m/s)	X 3.281	= feet/second (ft./sec.)
feet/minute (ft./min.)	X 0.3048	= meter/minute (m/min)	meters/minute (m/min)	X 3.281	= feet/minute (ft./min.)
TEMPERATURE					
°Celsius = 0.556 (°F - 32)			°Fahrenheit = (1.8°C) + 32		
COMMON METRIC PREFIXES					
mega	(M)	= 1,000,000 or 10 ⁶	deci	(d)	= 0.1 or 10 ⁻¹
kilo	(k)	= 1,000 or 10 ³	centi	(c)	= 0.01 or 10 ⁻²
hecto	(h)	= 100 or 10 ²	milli	(m)	= 0.001 or 10 ⁻³
deka	(da)	= 10 or 10 ¹	micro	(µ)	= 0.000.001 or 10 ⁻⁶

